

# ROD LOCK COIL SIDE ENTRY

The BOP  
That Clamps



## Key Features

- Coiled Tubing Side Entry Cleanout
- Lockout Clamp
- BOP
- Flow Tee

## Benefits

- Tubing cleanout without removing drive head
- Service any PC drive head without a rig
- Reduces rig cost
- Enhances safety

# ROD LOCK COIL SIDE ENTRY

The BOP  
That Clamps

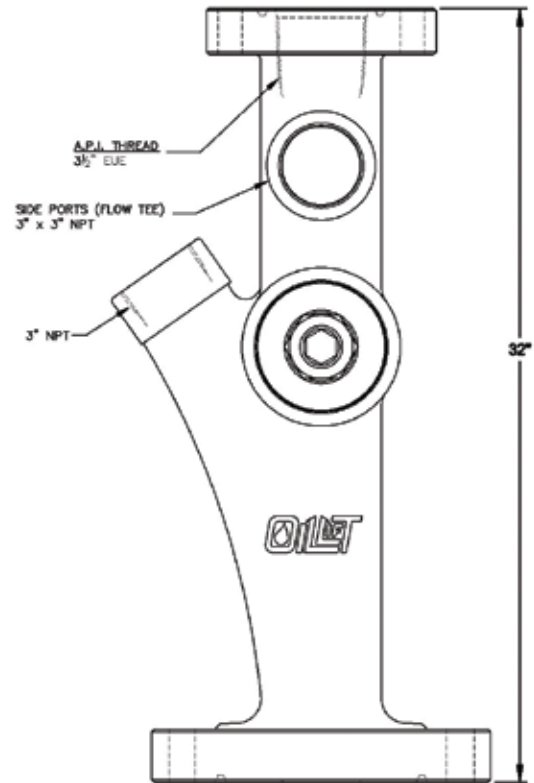

## CSE Advantages

- Insert Coiled Tubing for production tubing cleanout without removing the PC Pump Drive Head
- Flush-by rigs can use the side entry port to handle sand laden produced fluid rather than pushing it down the flow line
- Side Entry Port located below the BOP so the BOP is not disabled by the coiled tubing
- Perform Flush-by and coil tubing clean out simultaneously
- Complemented by the Oil Lift Coiled Rod Drive head system

## Specifications

- 3" NPT Side Entry Port
- BOP Rated at 3000 PSI
- Rod Lock rated at 25,000 pound of polished rod weight
- based on 800 ft-lb torque on clamp bolts
- Proof Load 40,000 pounds without slipping
- Proof Torque 1000ft-lb
- Pressure balanced for low actuating torque
- Through Bore 3 1/8"
- Rams available for 7/8" 1" 1 1/8" 1 1/4" 1 1/2"
- Top Flange 3 1/8" 3000# API R3
- Bottom Flange 7 1/16" 2000# API R45
- Other flange sizes available on request

## CSE Safety Advantages

- Eliminate the hazards associated with drive head removal for coiled tubing cleanouts
- Constant well control - BOP rams are located above the Coil Tubing Entry Port

## Rod Lock Safety Advantages

- Eliminate having to suspend a PC drive on the winch line while holding the rod weight on the draw works
- No Need for someone to work under a suspended drive head to install a hinged lock out clamp
- The polished rod is locked and cannot move while someone is working on the drive head

**OILIFT**  
Technology Inc  
*The Problem Solver*

#37 19 Aero Drive NE.  
Calgary, Alberta, Canada T2E 8Z9  
Phone: (403) 291-5300  
www.oillifttechnology.com  
sales@oillifttechnology.com

Suite 10, Reinhart Industrial Park  
Lloydminster, Alberta, Canada  
Phone: (780) 875-6830

#4, 5402 - 55 Avenue  
Bonnyville, Alberta, Canada  
Phone: (780) 573-2686

2803 Inland Street  
Farmington, New Mexico  
Phone: (505) 327-1226

2/41 Bellrick Street  
Acacia Ridge  
Queensland 4110  
Australia